

LUNE flush mount

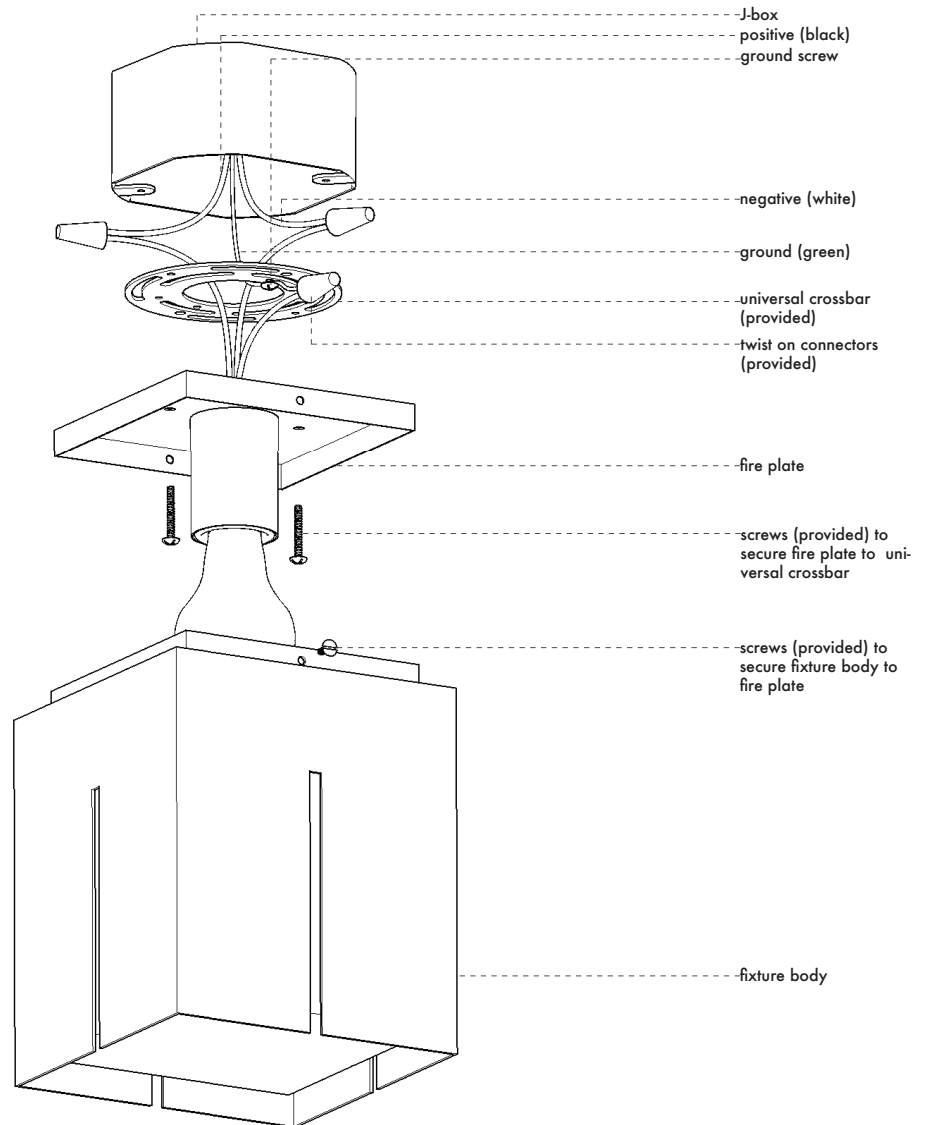

WIRING INSTRUCTIONS

1. Attach universal crossbar to J-box, aligning holes to desired location in regard to mounting plate screw holes.
2. Connect positive supply wire (typically black or the smooth, unmarked side of the two-conductor cord) to positive fixture lead with appropriately sized twist on connector.
3. Connect negative supply wire (typically white or the ribbed, marked side of the two-conductor cord) to negative fixture lead.
4. Please refer to the grounding instructions to complete all electrical connections.
5. Tuck the connected wires into the junction box. Align screw holes from fire plate to the universal crossbar. Thread the screws through, tightening the mounting plate flush to the ceiling.
6. Raise fixture body up over mounting plate. Secure at sides with provided screws.

GROUNDING INSTRUCTIONS

For positive grounding in a 3-wire electrical system, fasten the fixture ground wire (typically copper or green plastic coated) to the fixture mounting crossbar with the ground screw.

Note: On straps for screw support fixtures, first install the two mounting screws in strap. Any remaining tapped hole may be used for the ground screw.

LIGHT BULB REPLACEMENT

It's recommended to use a soft cloth or gloves when handling the fixture.

Remove screws at sides of fixture body to release from mounting plate.

Unscrew bulb and replace.

Return fixture body and tighten screws.